

IG series

- Pushbutton switches for joystick application
- bushing \varnothing 12 mm • momentary NO or NC/NO



DISTINCTIVE FEATURES

Last minute snappable plunger

Strong tactile feedback

Different voltages for LED backlight



ENVIRONMENTAL SPECIFICATIONS

- Operating and storage temperature: $-40\text{ }^{\circ}\text{C}$ to $+85\text{ }^{\circ}\text{C}$ ($-40\text{ }^{\circ}\text{F}$ to $+185\text{ }^{\circ}\text{F}$)
- Front panel sealing:
 - IPX7 according to IEC 60529
 - IPx9K according to DIN 40050-9
- Salt spray: IEC60068-2-11 test Ka (96h)
- Vibrations (random, 3 axis) per ISO 15003 level 3 : 10-350Hz, 2 hours per axis
- Vibrations (resonances frequency research) per ISO 15003 level 3 : 10-2000Hz
- Vibrations (dwell test) per ISO 15003 level 3 : 2g amplitude and 1 octave/min for 90 minutes
- Shock Resistance per ISO 15003 level 3 : 3 semi-sinusoidal impulse 500m/s^2 11ms on 3 axis



ELECTRICAL SPECIFICATIONS

- Electrical function: Momentary (NO and NC/NO)
- Max. current/voltage rating with resistive load:
 - Gold plated contact (0): 50 mA 28 VDC, 1,000,000 cycles
 - Silver contact (1): 2 A 28 VDC, 100,000 cycles
- Dielectrical strength: 1500 Vrms between terminals
- Initial contact resistance: 100 mOhms max
- Insulation resistance: 1 Gohms at 500 VDC



GENERAL SPECIFICATIONS

- Total travel: $2\text{ mm} \pm 0.4\text{ mm}$
- Typical operating force: $9\text{ N} \pm 2\text{ N}$
- Maximum applicable force: 50 N in all axes
- Hand soldering with lead-free alloy solder wire type SAC 305 (flux amount 2,2%): temperature $337\text{--}381\text{ }^{\circ}\text{C}$. Standard application time is 3s.
- Mechanical life: 1,000,000 cycles

The company reserves the right to change specifications without notice.



IG series

Pushbutton switches for joystick application
 • bushing Ø 12 mm • momentary NO or NC/NO

MATERIALS

- Case: Thermoplastic, UL94-V0
- Actuator: ABS UL94-Hb
- Bushing: Thermoplastic
- Membrane: fluorinated silicone, black
- Contacts:
 - 0: brass, gold plated
 - 1: silver
- Output wires: 15mm long 24AWG for LED version only

PANEL MOUNTING

- Panel thickness: 1.5 to 5.5 mm
- Torque: 0.55 Nm applied to nut
- Panel cut-out:

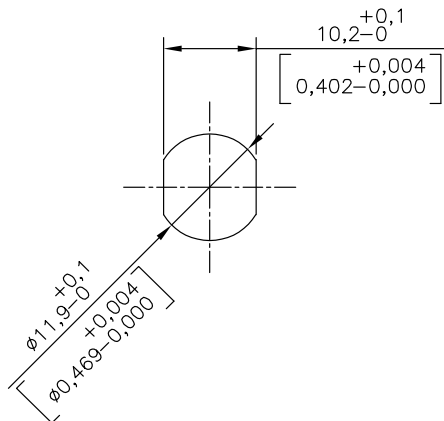

ELECTRICAL DIAGRAMS

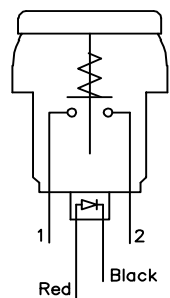

Function 3 (NO)
Illuminated

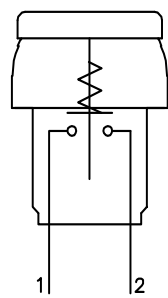

Function 3 (NO)
Non Illuminated

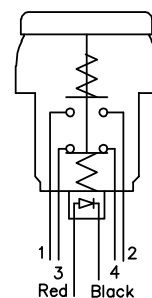

Function 5 (NC/NO)
Illuminated

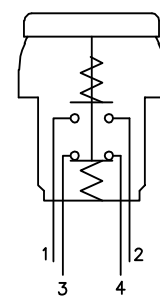

Function 5 (NC/NO)
Non Illuminated

Pushbutton switches for joystick application
 • bushing Ø 12 mm • momentary NO or NC/NO



BUILD YOUR PART NUMBER

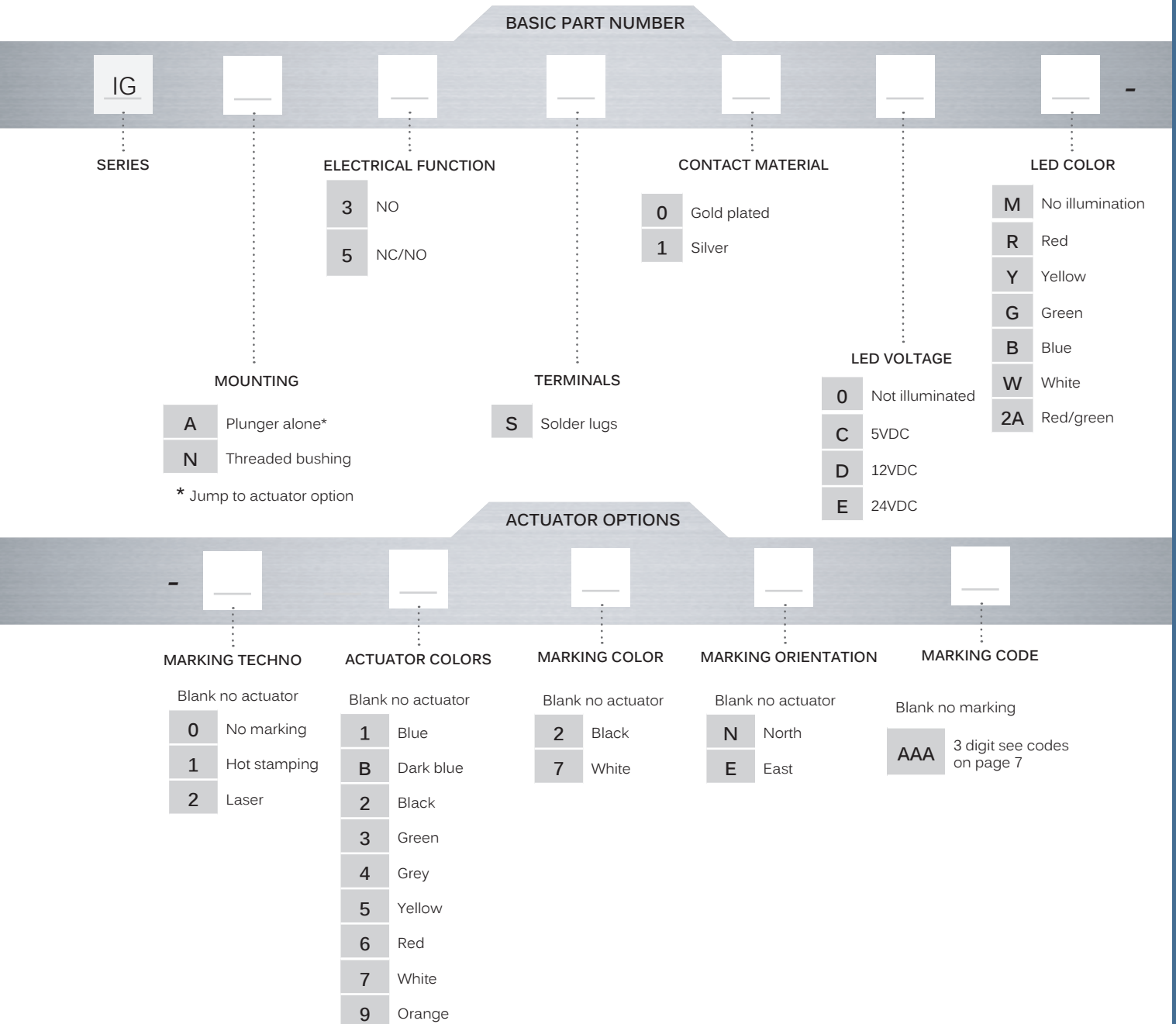

ABOUT THIS SERIES

On the following pages, you will find successively basic part numbers of switches and options in the same order as in above chart.

Mounting accessories: standard hardware supplied : U166 hex nut. Standard and special hardware is presented in the «Hardware» section of website.

IG series

Pushbutton switches for joystick application
 • bushing \varnothing 12 mm • momentary NO or NC/NO

MODELS



IGN*S*



IGA*

Please note that the body can be sold separately from the cap.
 For detailed drawings see below assemblies with cap.

SOLDER LUG TERMINALS NON-ILLUMINATED - NO



IGN3S*0M-*

IGN3S00M-06

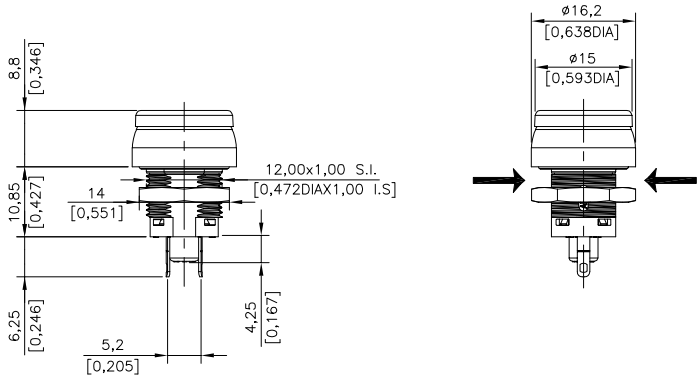
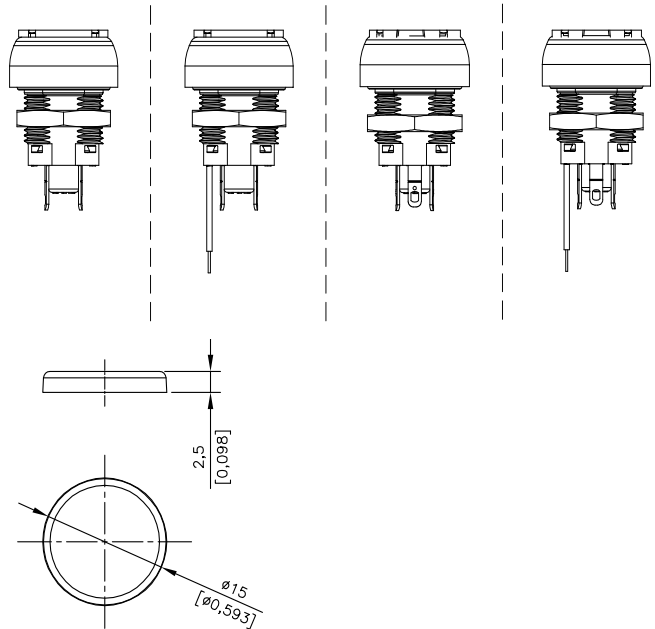

SOLDER LUG TERMINALS ILLUMINATED - NO



IGN3S*-*

IGN3S00DB-227NXU

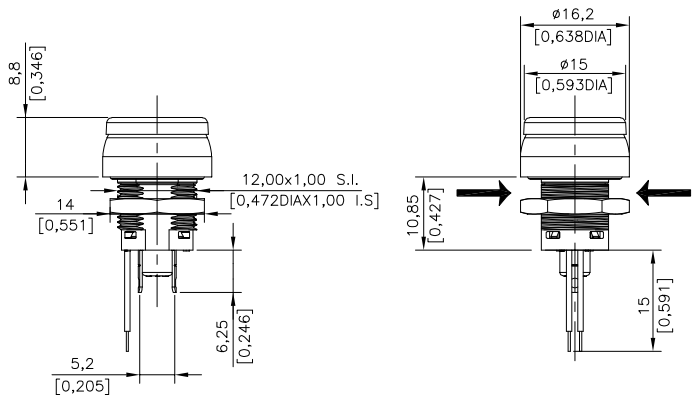

IG series

Pushbutton switches for joystick application
 • bushing Ø 12 mm • momentary NO or NC/NO

SOLDER LUG TERMINALS ILLUMINATED - NC/NO



IGN5S*0M-*

IGN5S10M-152EX41

SOLDER LUG TERMINALS NON-ILLUMINATED - NC/NO



IGN5S*-*

IGN5S1D2A-267NXYU

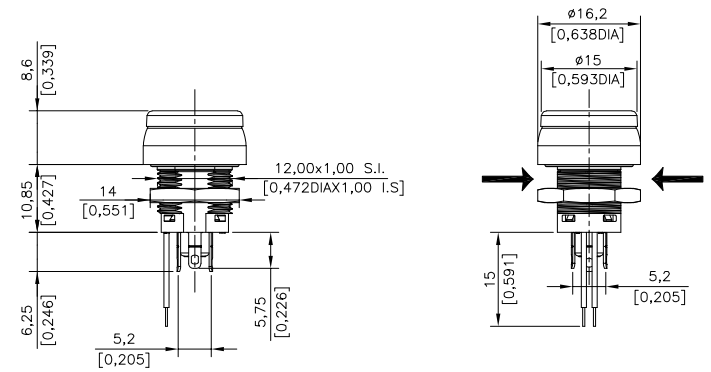
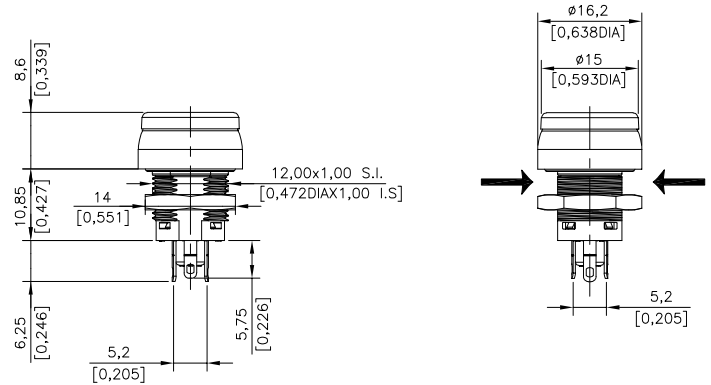

CONTACT MATERIAL



- 0 Brass, gold plated
- 1 Silver

LED VOLTAGE



- 0 Non illuminated
- C 5VDC
- D 12VDC
- E 24VDC

LED COLORS



- M Non-illuminated
- R Red
- Y Yellow
- G Green
- B Blue
- W White
- 2A Red/green

IG series

Pushbutton switches for joystick application
 • bushing Ø 12 mm • momentary NO or NC/NO

MARKING TECHNOLOGY



- Blank No actuator
- 0 No marking
- 1 Hot stamping
- 2 Laser



No marking



Hot stamping



Laser

CAPS Can be ordered separately, begin part number with IGA and follow the codification guide from here.

ACTUATOR COLORS



- Blank No actuator
- 1 Blue
- B Dark blue
- 2 Black
- 3 Green
- 4 Grey
- 5 Yellow
- 6 Red
- 7 White
- 9 Orange

MARKING COLOR



- Blank No actuator
- 2 Black
- 7 White

MARKING ORIENTATION



- Blank No marking
- N North
- E East



Pushbutton switches for joystick application
 • bushing Ø 12 mm • momentary NO or NC/NO

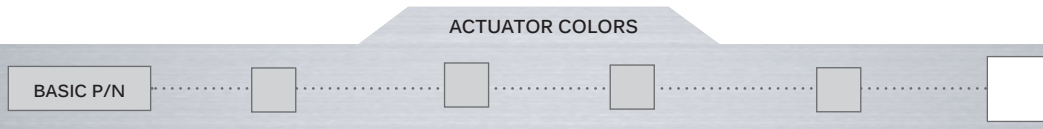

Logo
Dimension

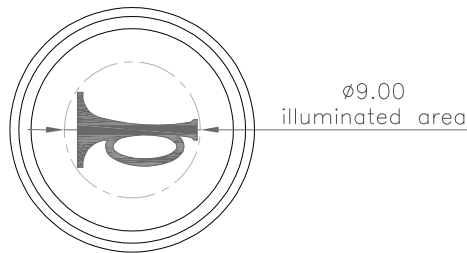

Most symbols meet the ISO 7000 standard “graphical symbols for use on equipment” (code given in bracket in the description).

Contact us for symbols not featured in the following table

Please note that all these symbols may not already exist as standard and could increase the lead time of the first order.

CODE	SYMBOL	DESCRIPTION
X41		Horn (0244)
X49		Differential lock (1662)
XAN		Loader bucket, float (1441)
XCD		Symbol 'Dot'
XKH		Illuminated ring
XYU		Symbol 'IDLE'
XN9		Symbol 'Power'